

7

5

3

1

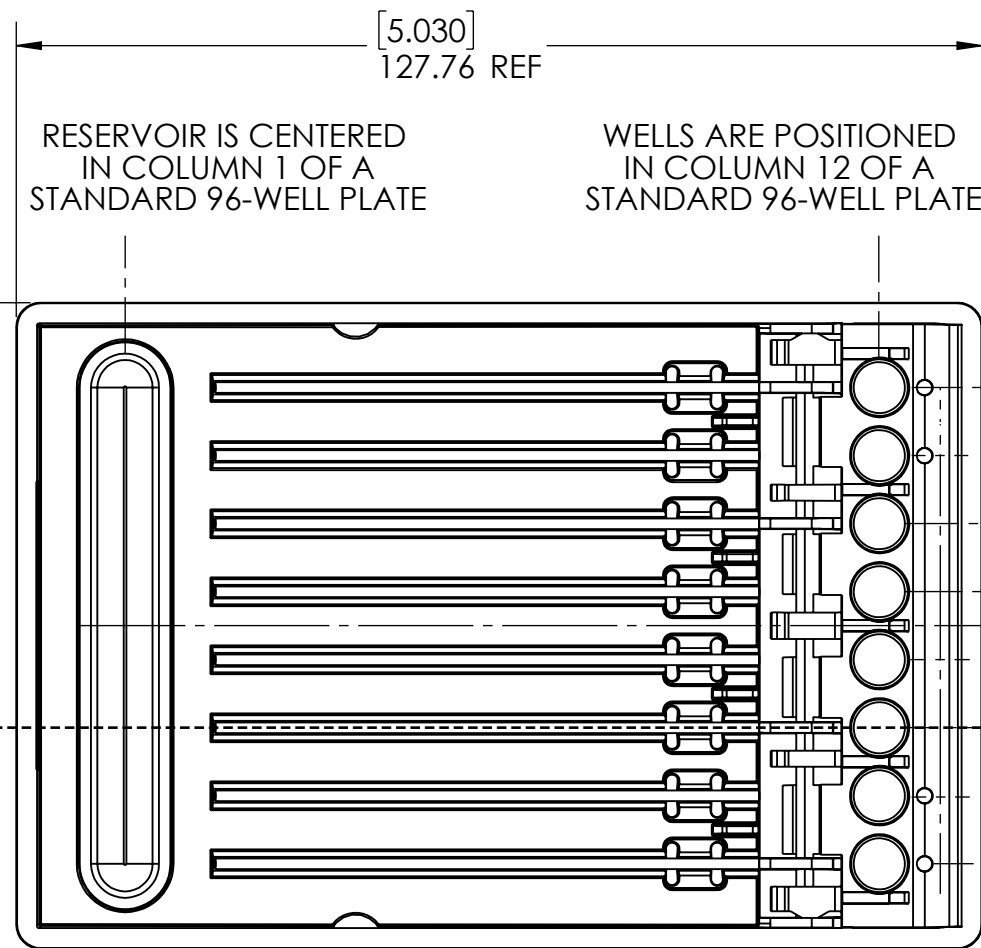

SALIENT DIMENSIONS*

	TOP OF FLIP TAB mm [IN.]	BOTTOM OF WELL mm [IN.]
CHECKIT GO 1 μL**	16.40 [.646]	9.14 [.360]
CHECKIT GO 2 μL**	16.40 [.646]	9.14 [.360]
CHECKIT GO 5 μL	16.40 [.646]	7.72 [.304]
CHECKIT GO 10 μL	16.40 [.646]	7.72 [.304]
CHECKIT GO 20 μL	16.40 [.646]	7.34 [.289]
CHECKIT GO 50 μL	16.53 [.651]	6.57 [.259]

* DIMENSIONS IN THIS TABLE MAY BE UP TO 0.5mm GREATER DUE TO FIT OF ASSEMBLED PARTS.

** WE SUGGEST CONTACT DISPENSING FOR SMALLER VOLUMES SUCH AS 2 μ L AND LESS.

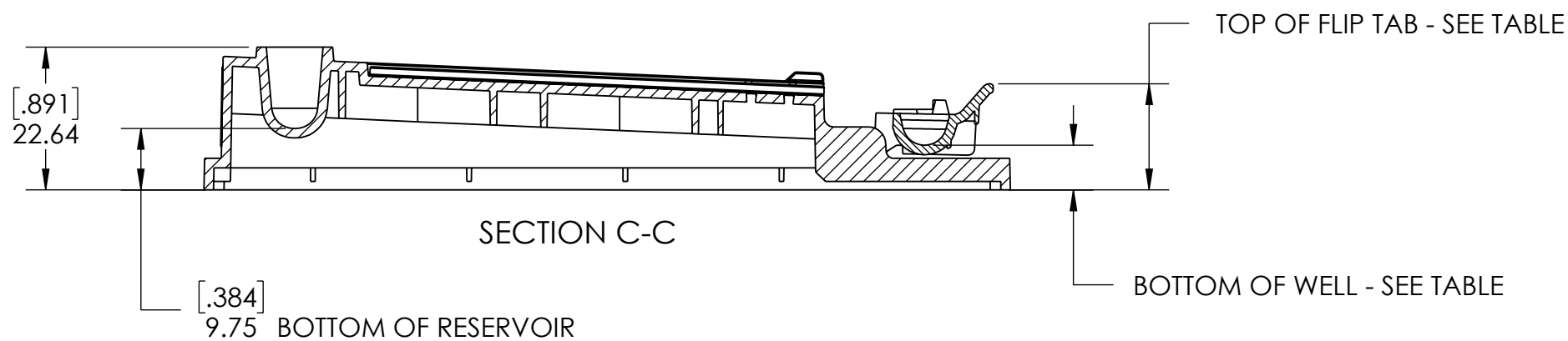

- NOTES:
1. THE CHECKIT GO CARTRIDGE CONFORMS TO THE ANSI SLAS 4-2004 STANDARD FOR MICROPLATE WELL POSITIONS.
 2. DIMENSIONS ARE IN MM [INCHES].

THE INFORMATION CONTAINED IN THIS DRAWING IS THE SOLE PROPERTY OF NEXT ADVANCE, INC. ANY REPRODUCTION IN PART OR WHOLE WITHOUT THE WRITTEN PERMISSION OF NEXT ADVANCE, INC. IS PROHIBITED.



Next Advance, Inc.
2113 NY 7
Troy, NY 12180 USA
Phone (518) 674-3510

DO NOT SCALE DRAWING

THIRD ANGLE PROJECTION

CHECKIT GO CARTRIDGE INTERFACE DRAWING		
SIZE B	DWG NO. 7053534	REV 08
SCALE 1:1		SHEET 1 OF 1

7

5

3

1